

Basic version NV KAT (closed-loop)

Engine 116.963 starting 1984 (optional version)

A. General

The CIS injection system is equipped with a lambda control. The principle components are O₂ sensor, electronic control unit and frequency valve.

The fuel pump relay does not feature decel fuel cutoff.

The vehicles must only be operated with unleaded regular or premium fuel to avoid damage to parts sensitive to lead (O₂ sensor and catalyst).

The engines are low-compression ($\epsilon = 8.3$). The piston crown features a 6.5 mm deep recess.

A fuel evaporation control system is fitted to reduce the fuel vapours flowing to the atmosphere (see Group 47).

An air conditioning or automatic climate control system in combination with a fuel cooler (47–400) is fitted as standard.

Identification vacuum lines

The basic colour of vacuum lines for the emission control system is transparent (white).

Additional colour stripes are used to facilitate identification of the individual functions.

Lines originating at the vacuum source (suction lines) **have only one colour stripe.**

Lines terminating at the vacuum-operated device (function lines) **have two colour stripes.**

Emission control system	Colour coding of originating vacuum line	Colour coding of terminating vacuum line
Ignition Advance	red	—
Air injection	blue	blue/purple

National version

- (J) (USA) Engine 116.96 starting model year 1981
(J) (USA) Engine 117.96 starting model year 1984

A. General information

Engines 116.96 and 117.96 are equipped with a standard emission control system for the (USA) national version for Federal and California vehicles.

Identification of vacuum lines

The basic colour of the vacuum lines for the emission control system is transparent (white).

Additional colour stripes are used to facilitate identification of the individual functions.

Lines originating at a vacuum source (suction lines) have only one colour stripe.

Lines terminating at the vacuum-operated device (function lines) have two colour stripes.

Emission control system	Color coding of originating vacuum line	Color coding of terminating vacuum line
Ignition		
advance	red	—
retard ¹⁾	yellow	—
Air injection	blue	blue/purple

¹⁾ Starting model year 1982 ignition retard is no longer installed.

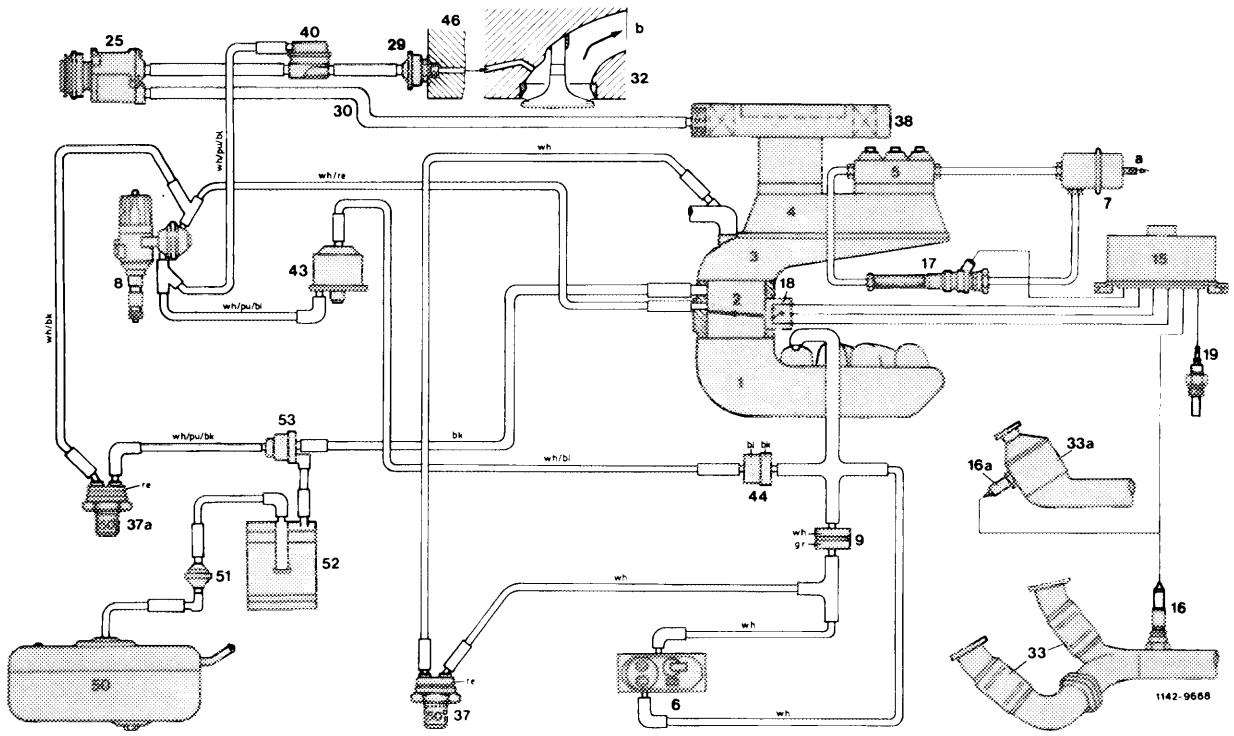

Function diagram engine 116 model year 1981

- | | | |
|--------------------------------------|------------------------------|-------------|
| 1 Intake manifold | 32 Cylinder head | bk = black |
| 2 Throttle valve housing | 33 Pre-catalyst (model 107) | bl = blue |
| 3 Air guide housing | 33a Pre-catalyst (model 126) | gr = green |
| 4 Air flow sensor | 37 Thermovalve 50 °C | pu = purple |
| 5 Fuel distributor | 37a Thermovalve 50 °C | re = red |
| 6 Warm-up compensator | 38 Air cleaner | wh = white |
| 7 Damper | 40 Air shutoff valve | |
| 8 Ignition distributor | 43 Switchover valve | |
| 9 Throttle (orifice) | 44 Check valve (vacuum) | |
| 15 Control unit | 46 Timing housing cover | |
| 16 O ₂ probe (model 107) | 50 Fuel tank | |
| 16a O ₂ probe (model 126) | 51 Vent valve | |
| 17 Frequency valve | 52 Charcoal canister | |
| 18 Throttle valve switch | 53 Purge valve | |
| 19 Temperature switch 16 °C oil | | |
| 25 Air pump | a Leak connection | |
| 29 Check valve (injected air) | b To exhaust manifold | |
| 30 Intake line | | |

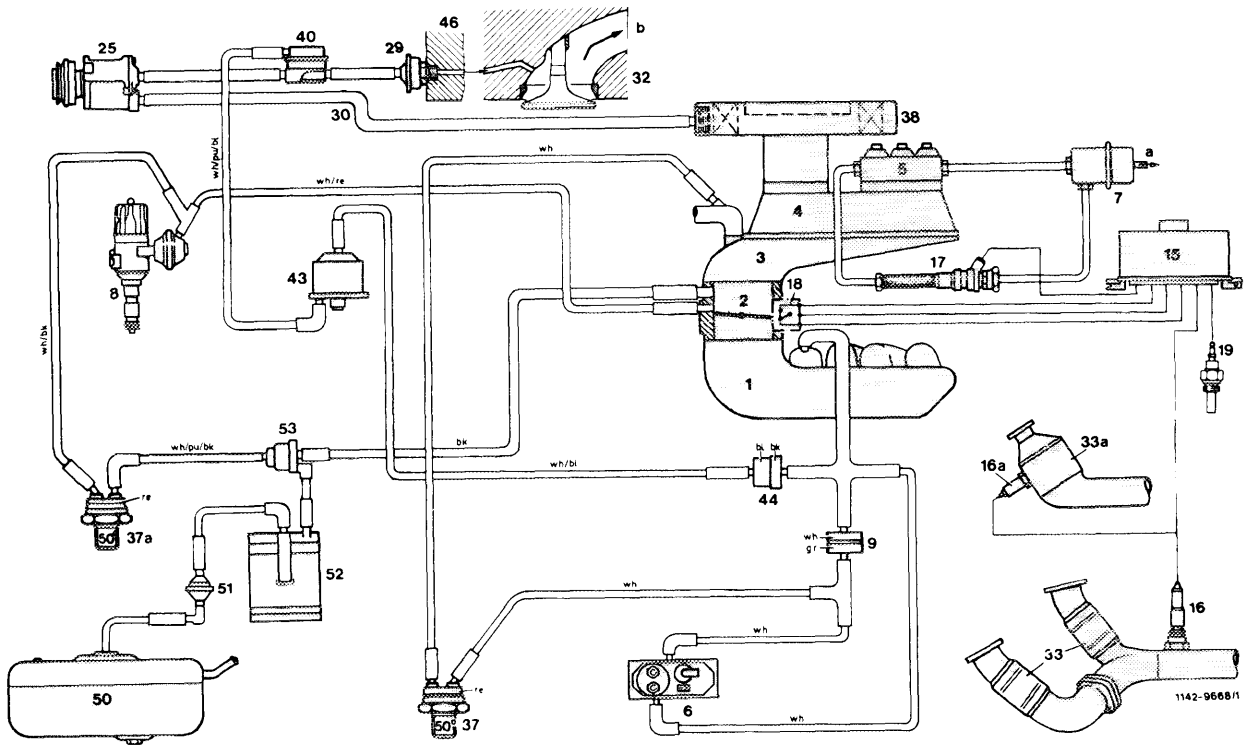

Function diagram engine 116 model year 1982

- 1 Intake manifold
- 2 Throttle valve housing
- 3 Air guide housing
- 4 Air flow sensor
- 5 Fuel distributor
- 6 Warm-up compensator
- 7 Damper
- 8 Ignition distributor
- 9 Throttle (orifice)
- 15 Control unit
- 16 O₂ probe (model 107)
- 16a O₂ probe (model 126)
- 17 Frequency valve
- 18 Throttle valve switch
- 19 Temperature switch 16 °C oil
- 25 Air pump
- 29 Check valve (injected air)
- 30 Intake line

- 32 Cylinder head
- 33 Pre-catalyst (model 107)
- 33a Pre-catalyst (model 126)
- 37 Thermovalve 50 °C
- 37a Thermovalve 50 °C
- 38 Air cleaner
- 40 Air shutoff valve
- 43 Switchover valve
- 44 Check valve (vacuum)
- 46 Timing housing cover
- 50 Fuel tank
- 51 Vent valve
- 52 Charcoal canister
- 53 Purge valve

- a Leak connection
- b To exhaust manifold

- bk = black
- bl = blue
- gr = green
- pu = purple
- re = red
- wh = white

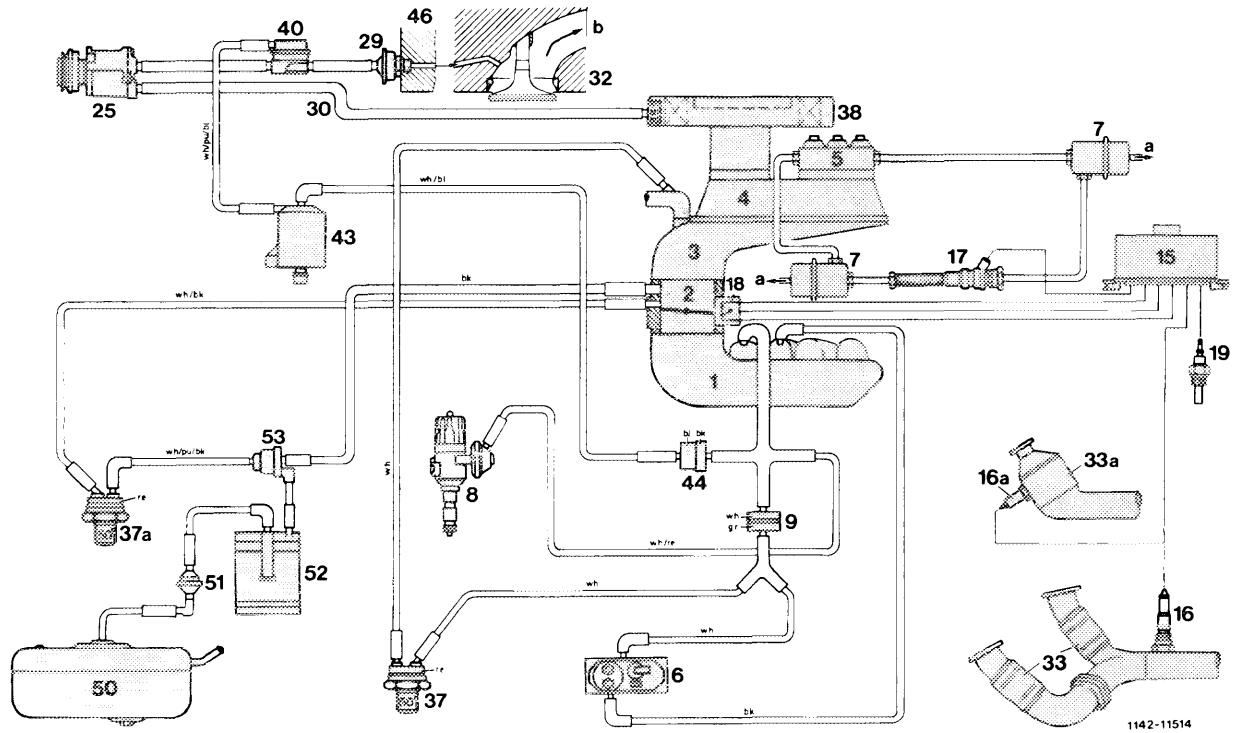

Function diagram engine 116 starting model year 1983, engine 117 starting model year 1984

- 1 Intake manifold
- 2 Throttle valve housing
- 3 Air guide housing
- 4 Air flow sensor
- 5 Fuel distributor
- 6 Warm-up compensator
- 7 Damper
- 8 Ignition distributor
- 9 Throttle (orifice)
- 15 Control unit
- 16 O₂ probe (model 107)
- 16a O₂ probe (model 126)
- 17 Frequency valve
- 18 Throttle valve switch
- 19 Temperature switch 16 °C oil
- 25 Air pump
- 29 Check valve (injected air)
- 30 Intake line

- 32 Cylinder head
 - 33 Pre-catalyst (model 107)
 - 33a Pre-catalyst (model 126)
 - 37 Thermovalve 50 °C
 - 37a Thermovalve 50 °C
 - 38 Air cleaner
 - 40 Air shutoff valve
 - 43 Switchover valve
 - 44 Check valve (vacuum)
 - 46 Timing housing cover
 - 50 Fuel tank
 - 51 Vent valve
 - 52 Charcoal canister
 - 53 Purge valve
- a Leak connection
b To exhaust manifold

- bk = black
- bl = blue
- gr = green
- pu = purple
- re = red
- wh = white

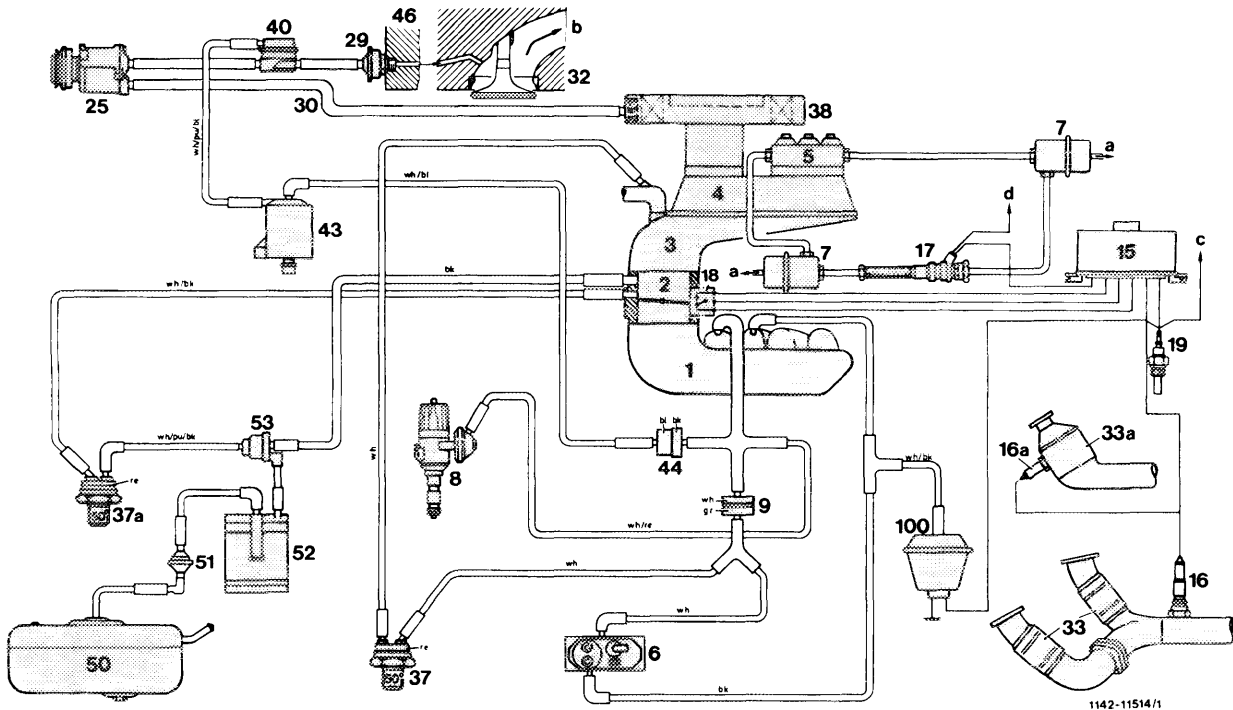

Function diagram with acceleration enrichment via pressure step switch, national version **USA**

Engine 116, 117 starting model year 1985

- | | | |
|---------------------------------------|---|-------------|
| 1 Intake manifold | 33a Pre-catalyst (model 126) | bk = black |
| 2 Throttle valve housing | 37 Thermovalve 50 °C | bl = blue |
| 3 Air guide housing | 37a Thermovalve 50 °C | gr = green |
| 4 Air flow sensor | 38 Air cleaner | pu = purple |
| 5 Fuel distributor | 40 Air shut-off valve | re = red |
| 6 Warm-up compensator | 43 Switchover valve | wh = white |
| 7 Damper | 44 Check valve (vacuum) | |
| 8 Ignition distributor | 46 Timing housing cover | |
| 9 Throttle (Orifice) | 50 Fuel tank | |
| 15 Control unit (lambda control) | 51 Vent valve | |
| 16 O ₂ sensor (model 107) | 53 Purge valve | |
| 16a O ₂ sensor (model 126) | 100 Pressure step switch | |
| 17 Frequency valve | | |
| 18 Throttle valve switch | a Leak connection | |
| 19 Temperature switch 16 °C oil | b to exhaust manifold | |
| 25 Air pump | c Control unit of idle speed control | |
| 29 Check valve (injected air) | d Plug connection, tail lamp wiring harness (contact 2) | |
| 30 Intake line | | |
| 32 Cylinder head | | |
| 33 Pre-catalyst (model 107) | | |

B. Lambda control ($\lambda = \text{lambda}$)

The lambda control system ensures that a constant air-fuel weight ratio is maintained at approx. 14.5 : 1 ($\lambda = 1$). That means, that an exact proportioning between the injected fuel and the air drawn in can be obtained. This is the ideal mixture ratio, which reduces, in conjunction with the 3-way catalysts, the emissions of HC, CO and NO_x in the exhaust gas to a minimum.

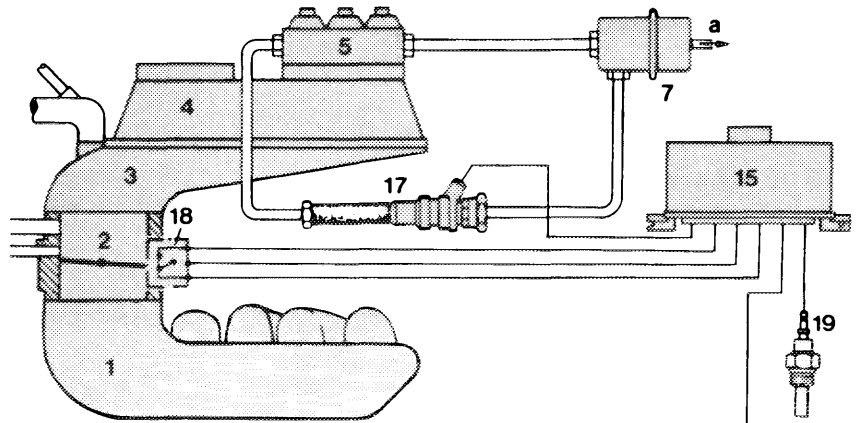

Function diagram lambda control
Engine 116 model year 1981/82

- 1 Intake manifold
- 2 Throttle valve housing
- 3 Air guide housing
- 4 Air flow sensor
- 5 Fuel distributor
- 7 Damper
- 15 Control unit
- 16 O₂ probe (model 107)
- 16a O₂ probe (model 126)
- 17 Frequency valve
- 18 Throttle valve switch
- 19 Temperature switch 16 °C oil
- 33 Pre-catalysts (model 107)
- 33a Pre-catalyst (model 126)

a Leak connection

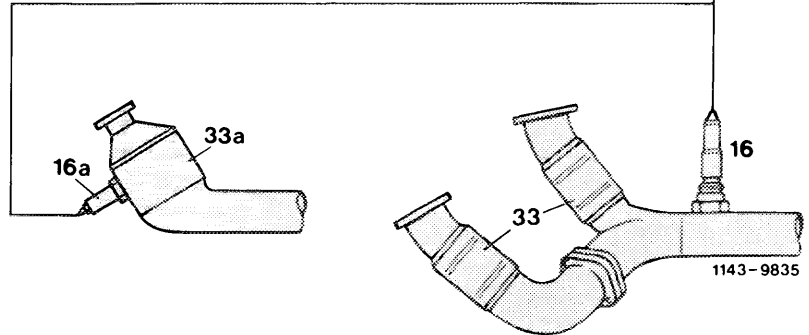

Function diagram lambda control
Engine 116 starting model year 1983
Engine 117 starting model year 1984

- 1 Intake manifold
- 2 Throttle valve housing
- 3 Air guide housing
- 4 Air flow sensor
- 5 Fuel distributor
- 7 Damper
- 15 Control unit
- 16 O₂ probe (model 107)
- 16a O₂ probe (model 126)
- 17 Frequency valve
- 18 Throttle valve switch
- 19 Temperature switch 16 °C oil
- 33 Pre-catalysts (model 107)
- 33a Pre-catalyst (model 126)

a Leak connection

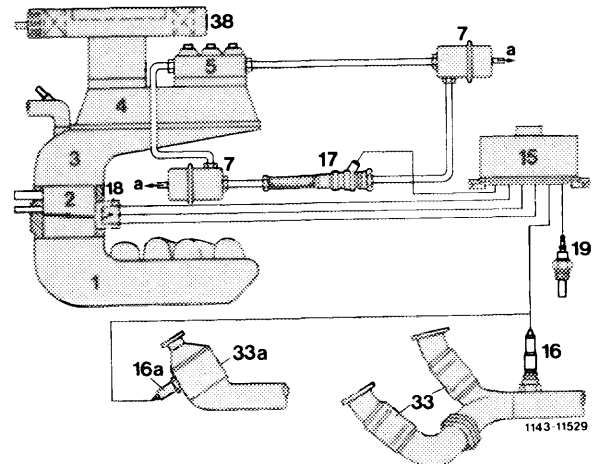

Components of lambda control:

O₂ probe (oxygen sensor)

The O₂ probe (oxygen sensor) is screwed into the front part of the exhaust pipe and on model 126 directly into pre-catalyst to measure the residual oxygen contents in the exhaust gases.

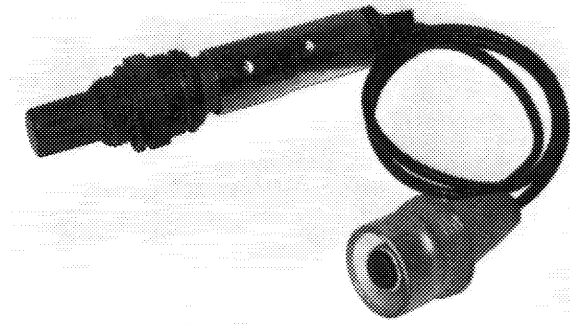

Model 107
Model year 1981/82

107-18785

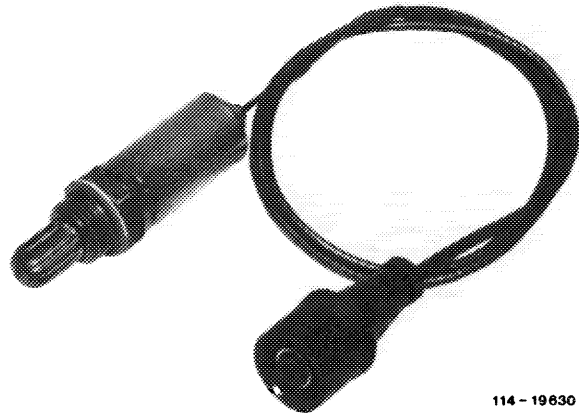

Model 126
Model year 1981/82

114-19630

Starting model year 1983, a uniform O₂ probe (oxygen sensor) with a new plug connection will be installed in models 107 and 126.



Model 107, 126
starting model year 1983

114-23991

The protective casing (12) protects the probe's ceramic insert (6) against mechanical damage. The outer part of the ceramic insert is in contact with the exhaust gases, the inner side with surrounding air. The ceramic surfaces are coated with a thin layer of gas-permeable platinum. In addition, a porous layer of ceramic is added on the exhaust side, which protects the platinum surface underneath against fouling from combustion materials, ensuring uniform long-life characteristics for O₂ probe (oxygen sensor).

- | | |
|----------------------------------|-----------------------------|
| 1 Exhaust gas side | 8 Contact spring |
| 2 Outside air side | 9 Protective cap |
| 3 Outer electro-conductive layer | 10 Crim connector |
| 4 Inner electro-conductive layer | 11 Connecting line |
| 5 Probe body with hexagon | 12 Protective tube |
| 6 Probe ceramic | 13 Exhaust gas intake slots |
| 7 Contact bushing | 14 Sealing ring |
| | 15 Fresh air intake slot |
| | 16 Insulator |

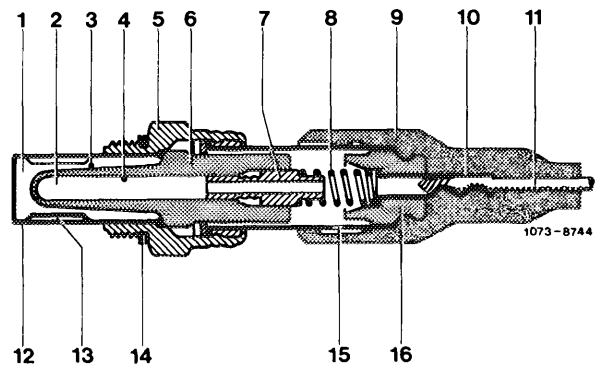

Operation

At a temperature of approx. 300 °C the ceramic material becomes conductive to the oxygen ions. A different amount of oxygen between either side (exhaust gas side and fresh air side) presents a chemical reaction between the adjoining surfaces and induces an electrical potential. The value of this potential represents the measurement for oxygen differential on both sides of the O₂ probe (oxygen sensor). The O₂ probe is highly sensitive at a range of $\lambda = 1$ and signals the electronic control unit that this is the desired value.

Control unit

On model 126 the control unit is located in righthand legroom behind lateral lining or on model 107 under leg support. A combination of printed circuits regulates the air-fuel mixture to an ideal value of $\lambda = 1$.

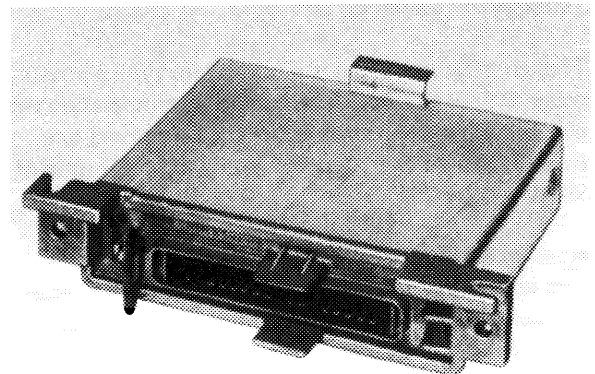

Frequency valve

The frequency valve is attached to the air flow sensor. It is connected to the fuel line from lower chamber of fuel distributor via pressure damper to the return line of the warm-up compensator.

The frequency valve regulates the differential pressure in fuel distributor.

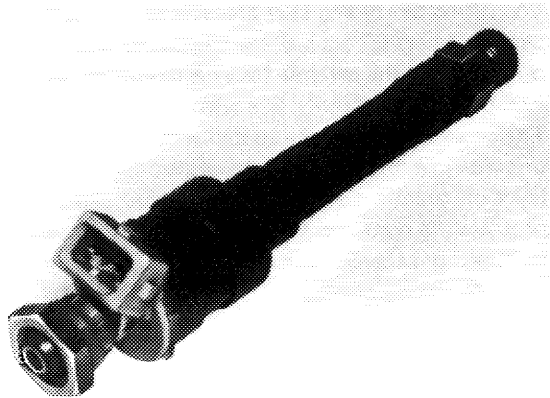

107-16794

Throttle valve switch

The Throttle valve switch is attached to throttle valve housing and has two functions: idle speed and full throttle contact.

Idle speed contact

The idle speed contact on throttle valve switch serves to narrow the control amplitude in control unit to obtain a stabilization of idle speed.



107-17070

Full throttle contact

When the vehicle is driven in full throttle range (throttle valve against full throttle stop) a firm on-off ratio of 60:40 (slightly richer) is set in control unit via full throttle contact.

Temperature switch oil $16 \pm 3 \text{ }^{\circ}\text{C}$

The temperature switch is screwed into timing housing cover. Below approx. $16 \text{ }^{\circ}\text{C}$ engine oil temperature the control unit is connected to negative via closed temperature switch and adjusted to a fixed on-off ratio of 60:40.

At approx. $16 \text{ }^{\circ}\text{C}$ engine oil temperature the temperature switch will open and thereby interrupt the negative connection. The control unit will continue to control the on-off ratio.

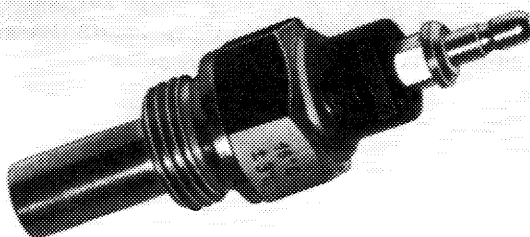

107-16798

Relay voltage supply

For voltage supply of lambda control on model 126 a relay is installed in fuse box or on model 107 in righthand legroom above fuse box.

Note: Starting model year 1982 the relays voltage supply and overvoltage protection have been combined. The new designation is relay voltage supply with overvoltage protection (refer to electric wiring diagram).

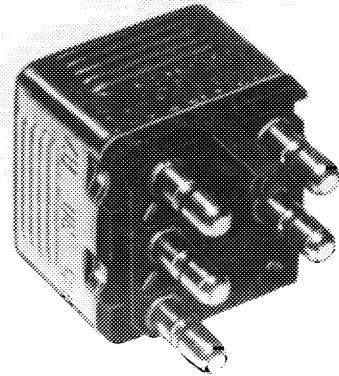

107-17461

Overvoltage protection

To prevent damage to components of lambda control, caused by increased voltage of vehicle circuit (quick charging of battery, loose battery poles) an overvoltage protection is attached prior to relay for voltage supply.

Note: Starting model year 1982 the overvoltage protection has been integrated in the voltage supply relay. A 10A fuse is installed on the top.

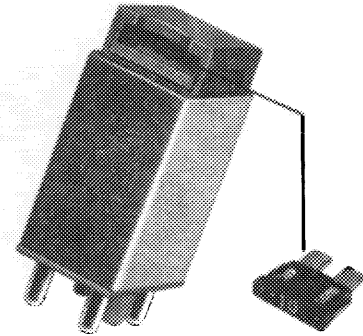

142-21756

Operation

At an operating temperature above 300 °C and depending on oxygen content in exhaust gases the O₂ probe indicates a voltage and thereby informs the control unit whether the air-fuel mixture is richer or leaner than $\lambda = 1$.

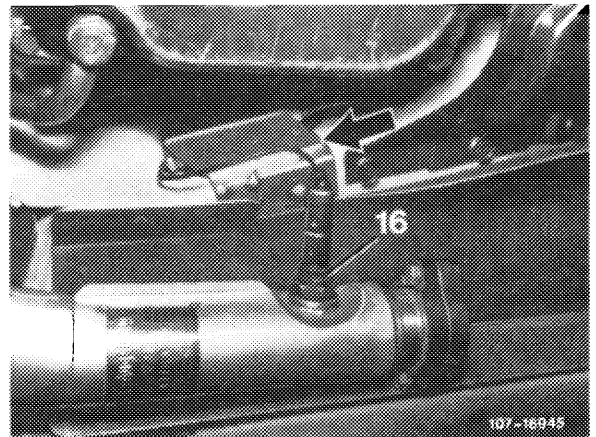

Model 107

107-16045

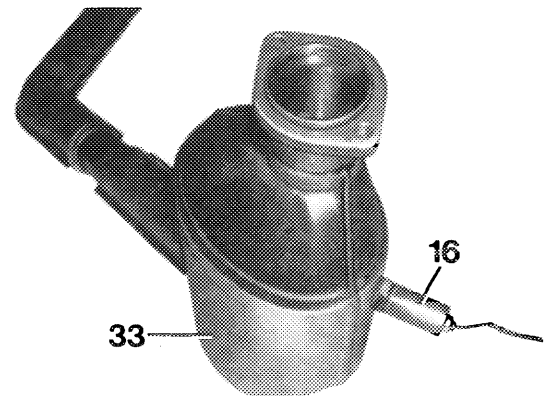

Model 126

114-19613

In control unit (15) the signal coming from the O₂ probe is converted into voltage impulses which are then transmitted to frequency valve (17).

Model 107

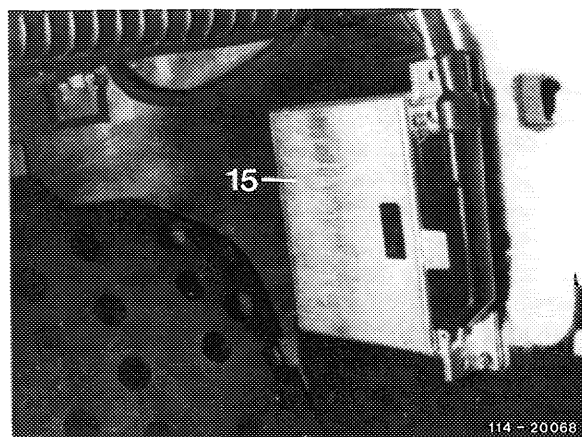
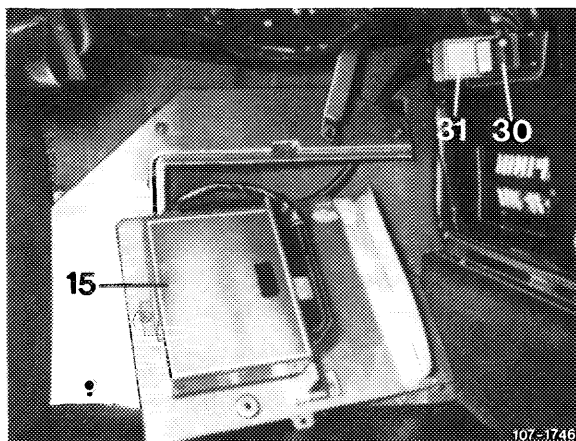

Model 126

The frequency valve is a magnetic valve which changes the differential pressure on control slit of slit carrier and thereby the injected fuel quantity in dependence of the arriving voltage signals (on-off ratio) (refer to 07.3 Fuel distributor).

When driving with opened throttle valve (full load) or at a temperature of engine oil below 16 °C, lambda control is inoperative. The frequency valve is operated via control unit at a fixed on-off ratio of 60:40. This means that the frequency valve is 60 % opened and 40 % closed.

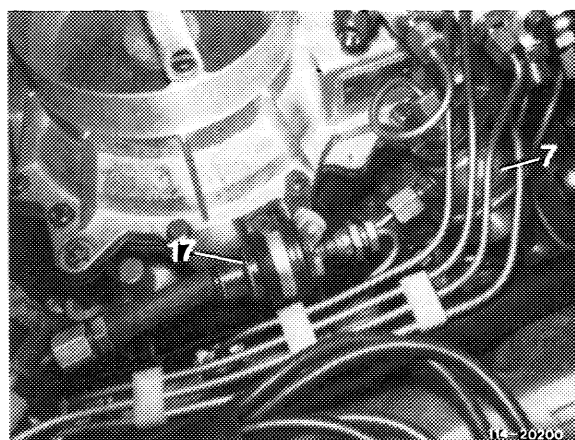

These two operating modes are activated by the throttle valve switch (18) or by oil temperature switch (19).

After 30 000 miles a warning lamp "O₂ probe" in instrument cluster indicates that the probe must be renewed.

In addition we recommend renewing the O₂ probe every 30 000 miles.

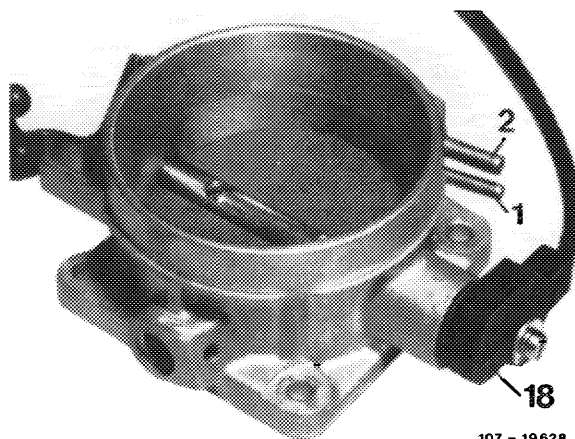

107 - 19628

Pressure step switch (USA) starting model year 1985

An electropneumatic pressure step switch (100) is fitted for enriching the mixture when accelerating.

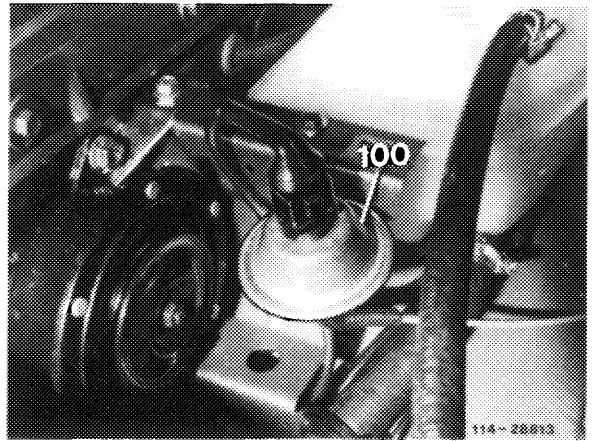

Operating

The change in pressure in the intake manifold which occurs when accelerating or when the accelerator pedal is depressed sharply is exploited by a pressure step switch to activate the control unit of the lambda control. It is also operational when the engine is at normal operating temperature.

When the engine is stationary, the switch (5) is opened by the spring (4). When the engine is running at a constant speed or load, the vacuum in the stop chamber (1) and in the bottom chamber (2) is identical as the orifice (2) balances the pressure.

- a To intake manifold
- b To 16 °C oil temperature switch
- M5 Engine ground

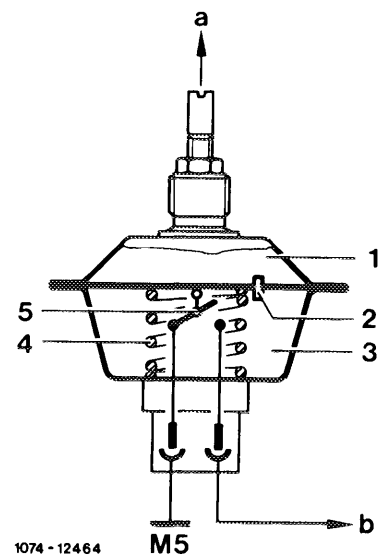

When the car is accelerated, the vacuum in the top chamber drops. The vacuum prevailing in the bottom chamber pulls the diaphragm down against the spring (differential pressure), the switch closes. The control unit of the lambda control is connected to ground, briefly applies a fixed on/off ratio 60 %, the mixture is enriched.

The switch remains closed until the vacuum in the top and bottom chambers is balanced through the orifice. Once the pressure is identical, the spring opens the switch, the ground to the control unit is interrupted, the mixture is no longer enriched.

C. Air injection

Air is injected into the hot zone behind the exhaust valves at certain engine operating conditions to improve emission levels.

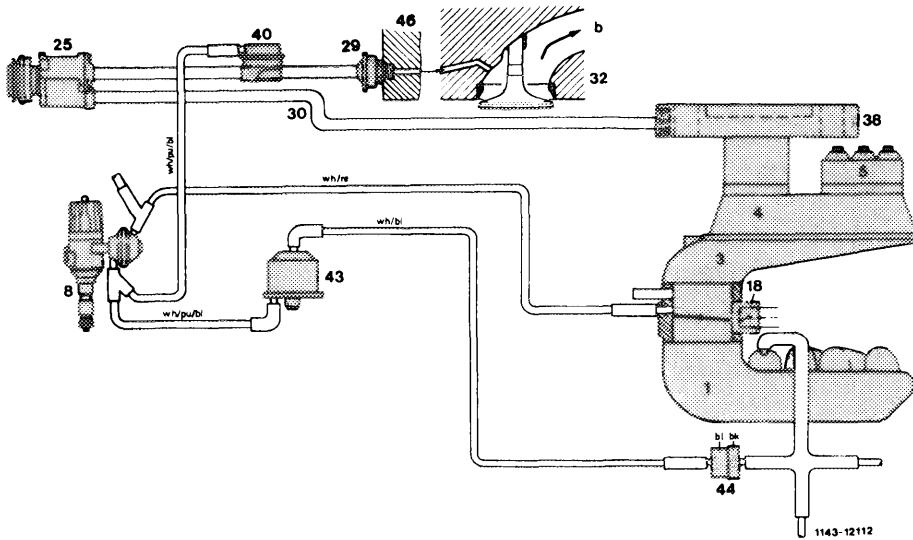

Function diagram engine 116 model year 1981

1 Intake manifold	30 Intake line	bk = black
3 Air guide housing	32 Cylinder head	bl = blue
4 Air full sensor	38 Air cleaner	pu = purple
5 Fuel distributor	40 Air shut-off valve	re = red
8 Ignition distributor	43 Switchover valve	wh = white
18 Throttle valve switch	44 Check valve (vacuum)	
25 Air pump	46 Timing housing cover	
29 Check valve (injected air)	b To exhaust manifold	

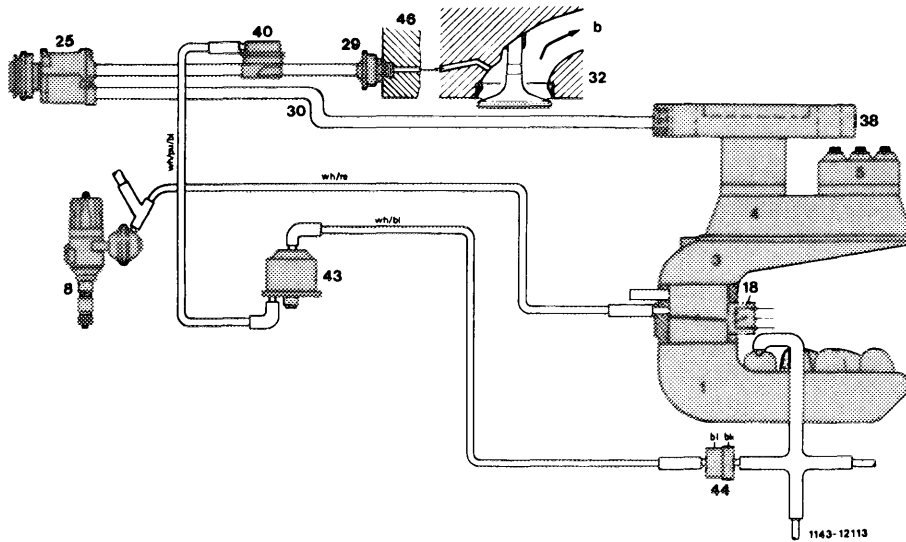

Function diagram engine 116 model year 1982

- | | | |
|-------------------------------|-------------------------|-------------|
| 1 Intake manifold | 30 Intake line | bk = black |
| 3 Air guide housing | 32 Cylinder head | bl = blue |
| 4 Air full sensor | 38 Air cleaner | pu = purple |
| 5 Fuel distributor | 40 Air shut-off valve | re = red |
| 8 Ignition distributor | 43 Switchover valve | wh = white |
| 18 Throttle valve switch | 44 Check valve (vacuum) | |
| 25 Air pump | 46 Timing housing cover | |
| 29 Check valve (injected air) | | |
- b To exhaust manifold

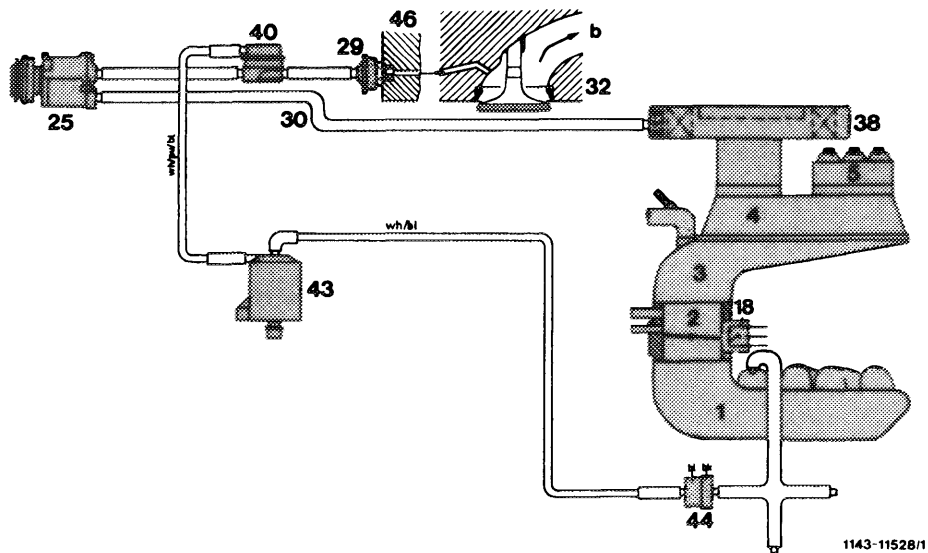

Function diagram engine 116 starting model year 1983, engine 117 starting model year 1984

- | | | |
|-------------------------------|-------------------------|-------------|
| 1 Intake manifold | 30 Intake line | bk = black |
| 3 Air guide housing | 32 Cylinder head | bl = blue |
| 4 Air full sensor | 38 Air cleaner | pu = purple |
| 5 Fuel distributor | 40 Air shut-off valve | re = red |
| 8 Ignition distributor | 43 Switchover valve | wh = white |
| 18 Throttle valve switch | 44 Check valve (vacuum) | |
| 25 Air pump | 46 Timing housing cover | |
| 29 Check valve (injected air) | | |
- b To exhaust manifold

Components of air injection:

Air cleaner with separate filter element

A separate filter element (arrow) is located inside air cleaner, through which the air pump draws in the required air free of noise.

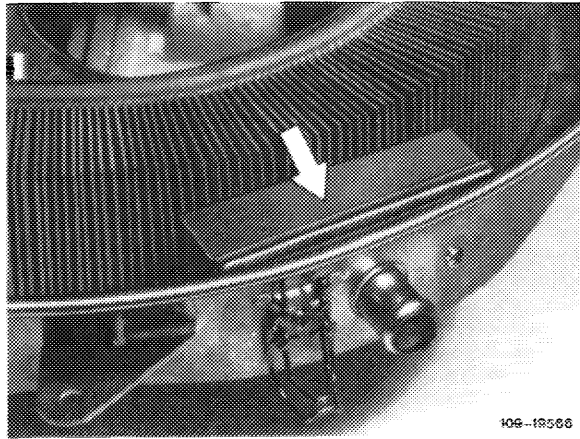

Air pump with electromagnetic clutch

The air pump is a maintenance-free vane-type pump which aspirates the air via two vanes. The electromagnetic clutch is switched on and off via control unit of lambda control and a relay (refer to electric wiring diagram).

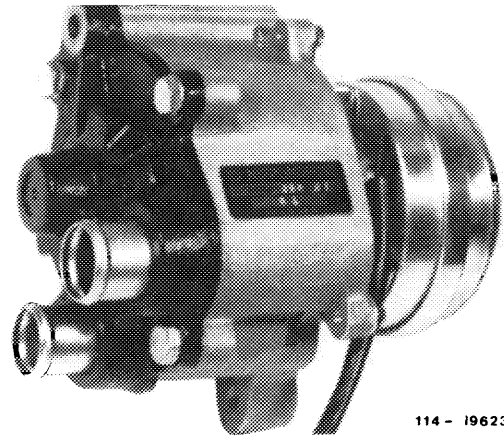

Air shutoff valve

The air shutoff valve is installed in contour hose between air pump and check valve and protects the air pump against backflow of exhaust gases, if any.

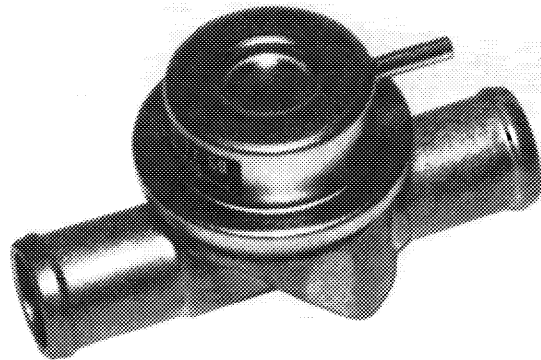

Note concerning installation position

On engine 116.961 the air shutoff valve (40) is offset by 180° for installation reasons.

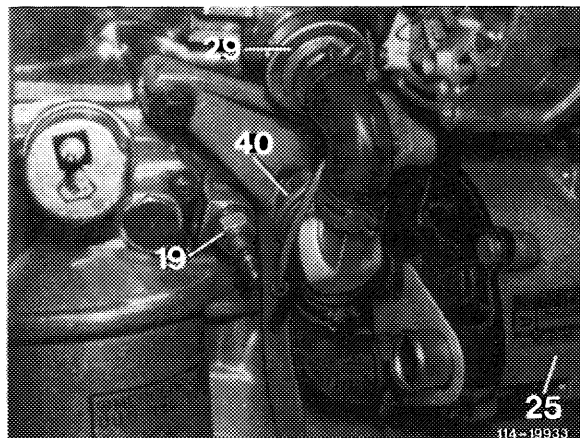

Installation position engine 116.960

Check valve (exhaust gas)

The check valve is screwed to timing housing cover and prevents hot exhaust gases from flowing back into system when the pump is switched off.

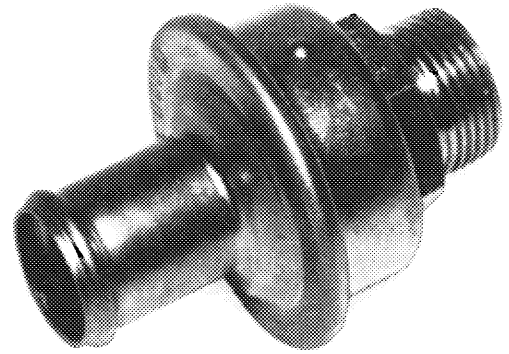

114 - 19621

Switchover valve

The switchover valve is attached to lefthand wheel-house and identified by its blue cap. The valve controls the vacuum for the air shutoff valve and for ignition retard.

Ignition retard is no longer installed starting model year 1982.

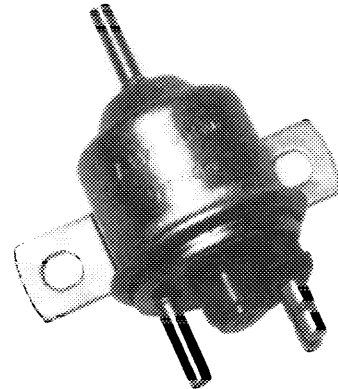

154 - 19622

Starting model year 1984 a new, standardized switchover valve will be installed.

In de-energized condition the small lateral and lower connecting pipes have a common passage. In energized condition, passage from upper to lateral connecting pipe should be open.

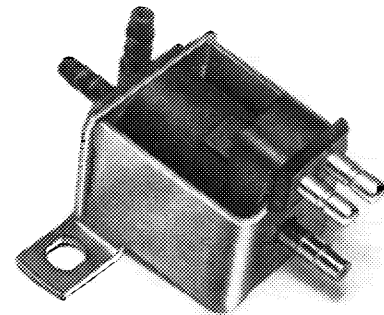

114 - 23813

Temperature switch 42 °C

The temperature switch is screwed at the rear into righthand cylinder head and opens at approx. 42 °C coolant temperature.

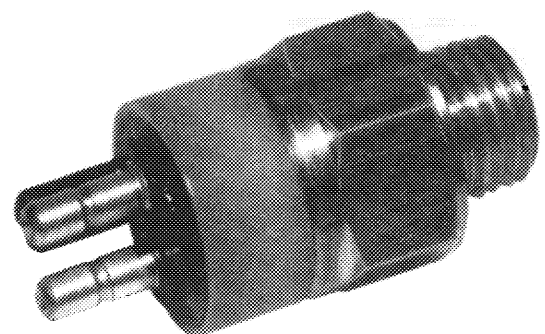

154 - 19627

Relay voltage supply

For voltage supply of switchover valve a relay is installed in fuse box or on model 107 in righthand legroom above fuse box.

Note: Starting model year 1982 the relay for voltage supply and for overvoltage protection have been combined. The new designation is relay voltage supply with overvoltage protection.

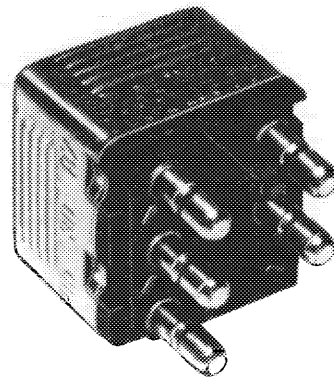

107-17461

Operation

Air injection proceeds only after all the three conditions named below have been met:

- Oil temperature $> 16^{\circ}\text{C}$.
- Coolant temperature $< 42^{\circ}\text{C}$.
- O_2 probe not operational (temperature $<$ approx. 300°C).

At these conditions the electromagnetic clutch of the air pump is connected by means of a relay (33, refer to electric wiring diagram). Simultaneously, the same relay actuates the switchover valve (43), which in turn releases the vacuum for air shutoff valve (40) as well as to vacuum retard unit (up to 1982). The vacuum pulls the diaphragm against spring force in upward direction and lifts the valve off its seat. Now the air pump, which is driven by a V-belt, can inject the air drawn out of air cleaner via shutoff valve (40), check valve (29) through ducts of timing housing cover and crankcase into exhaust ducts of cylinder heads.

The oxygen in the injected air encounters the hot exhaust gases for reaction in pre-catalyst.

To protect the catalysts against thermic overloads and to eliminate any influence on control operation of lambda control, air will be injected only under the conditions named above.

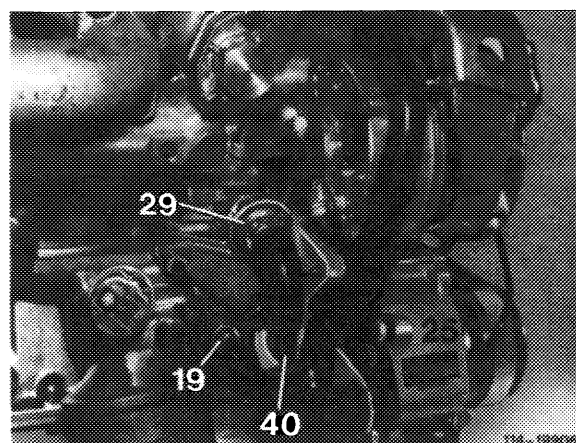
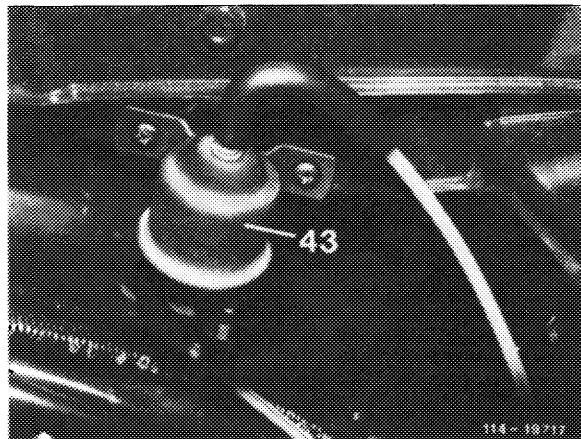

D. Catalysts

The catalysts are located in exhaust system in front of mufflers and are designed as 3-way catalysts. Constituents of CO (carbon monoxide), HC (hydrocarbons) and NO_x (nitric oxides) in exhaust gases are almost completely reduced or oxidized therein.

Model 107

- 16 O₂ probe
- 33 Pre-catalysts
- 35 Catalyst-muffler (silencer) combination

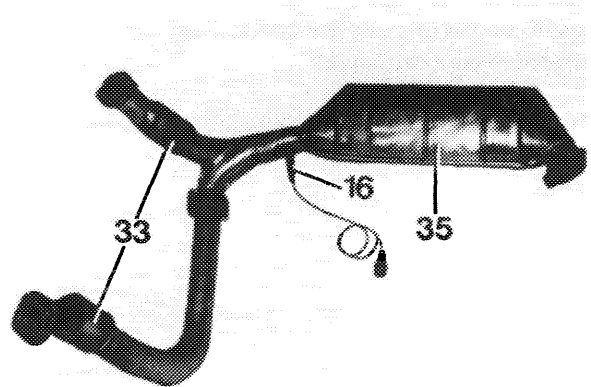

714 - 19614

Model 107

Pre-catalyst

The pre-catalyst comprises a monolith, a honeycomb-shaped steel body (1), which is pressed into exhaust pipe and welded therewith.

- 1 Monolith (steel body)

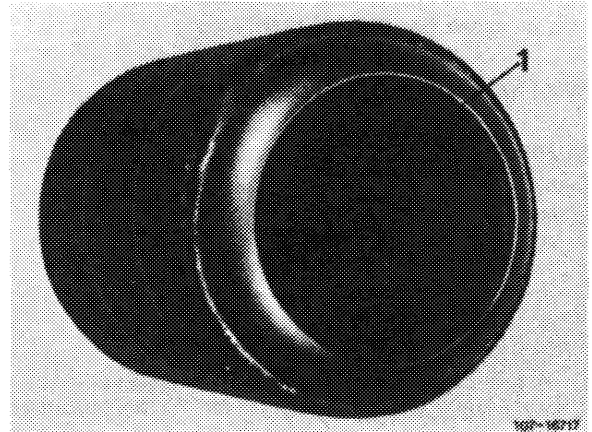

107 - 18717

Catalyst-muffler combination or underfloor catalyst

The catalysts are made of monoliths (3), honeycomb-shaped bodies of ceramic material which are elastically located in wire netting (2).

The noble metal applied to monoliths, the actual catalyst, accelerates reduction or oxidation of pollutants.

- 1 Housing
- 2 Wire netting
- 3 Monolith
- 4 Muffler

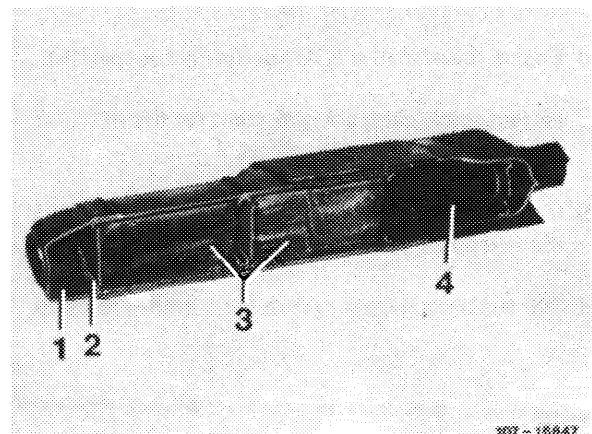

107 - 18647

Model 126

Primary and underfloor catalyst

Model 126 has a primary and an underfloor catalyst, which are similar in design and effect, but are different externally owing to the different installation position.



114-19612

The catalysts are made of monoliths (3), honeycomb-shaped bodies of ceramic material which are elastically located in wire netting (2).

The noble metal applied to monoliths, the actual catalyst, accelerates reduction or oxidation of pollutants.

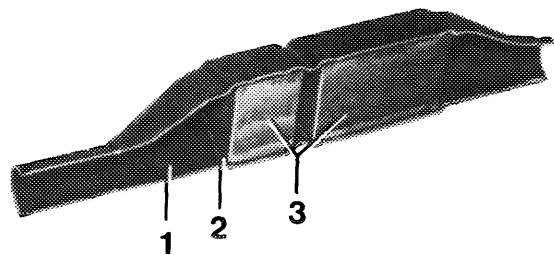

- 1 Housing
- 2 Wire netting
- 3 Monolith

107-16849

To keep the catalysts operational, operate engine with unleaded (leadfree) fuel only.

Avoid overheating of catalysts.

Extended overheating of catalyst will lead to catalyst damage, that is, the monoliths in catalyst are subject to melting.

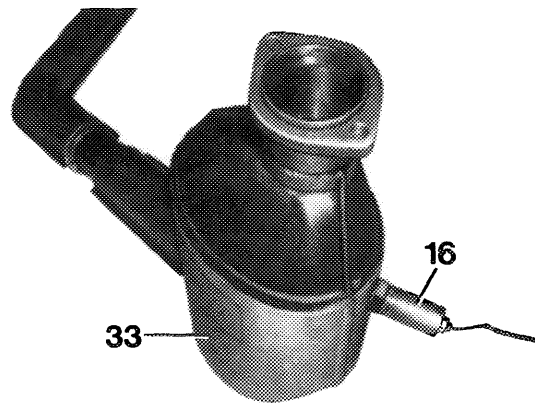

- 16 O₂ probe
- 33 Primary catalyst

114-19613

Overheating of catalyst may occur, if:

a) Engine maintenance is not performed as specified.

Perfect spark plugs are important for life of catalyst.

b) Irregularities on engine are excessively enriching the fuel-air mixture.

c) The emission control system is arbitrarily changed.

F. O₂ probe change indicator

Legal specifications are that the O₂ probe must be changed once after 30 000 miles or on Canada vehicles after 50 000 km. The required change is indicated by "O₂ sensor" (arrow) warning lamp which lights up in instrument cluster.

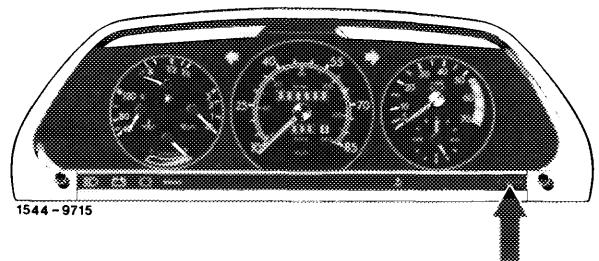

Operation

The mileage counter of tachometer generates a voltage by way of a magnetic field after attaining 30 000 miles or 50 000 km. The subsequently connected electronic system picks up this voltage and then switches on the indicator lamp in instrument cluster.

After changing the O₂ probe, make warning device inoperative by removing bulb (arrow). For this purpose, partially remove and install instrument cluster.

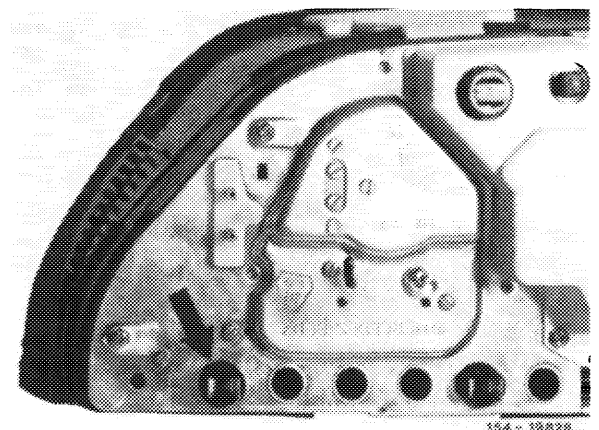

G. Electric wiring diagrams

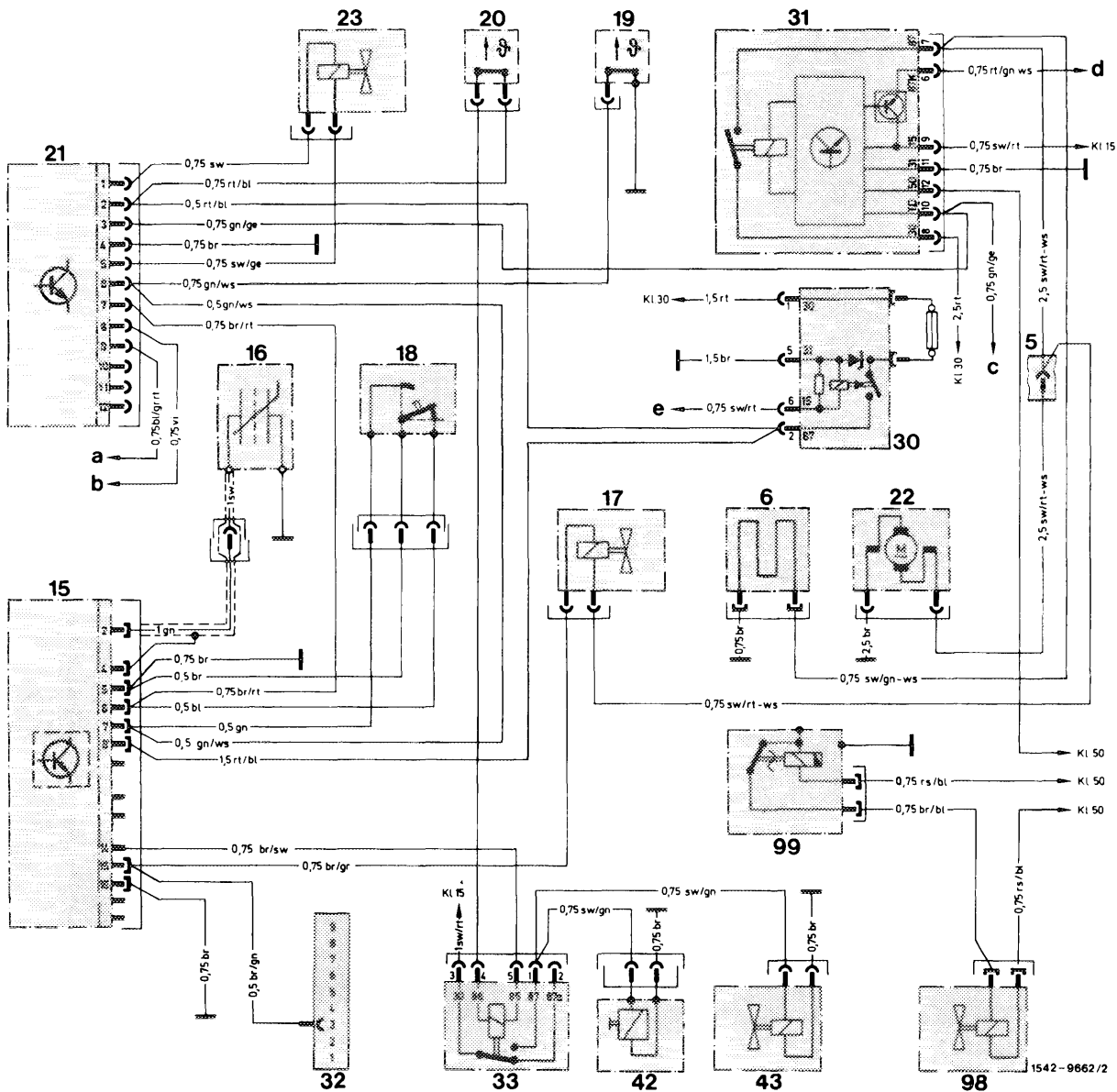

Lambda control, air injection and idle speed control engine 116 model year 1981

- 5 Clutch tail lamp harness
- 6 Warm-up compensator
- 15 Control unit lambda control
- 16 O₂ probe (oxygen sensor)
- 17 Frequency valve
- 18 Throttle valve switch
- 19 Temperature switch 16 °C oil
- 20 Temperature switch 42 °C coolant
- 21 Control unit electronic idle speed control
- 22 Fuel delivery pump

- 23 Idle speed adjuster
- 29 Relay voltage supply
- 30 Overvoltage protection
- 31 Relay fuel pump (electronic)
- 32 Diagnosis socket
- 33 Relay air injection
- 42 Magnetic clutch air pump
- 43 Switchover valve air injection
- 98 Cold start valve
- 99 Thermo time switch

- bl = blue
- br = brown
- ge = yellow
- gn = green
- gr = grey
- rs = pink
- rt = red
- sw = black
- vi = purple
- ws = white

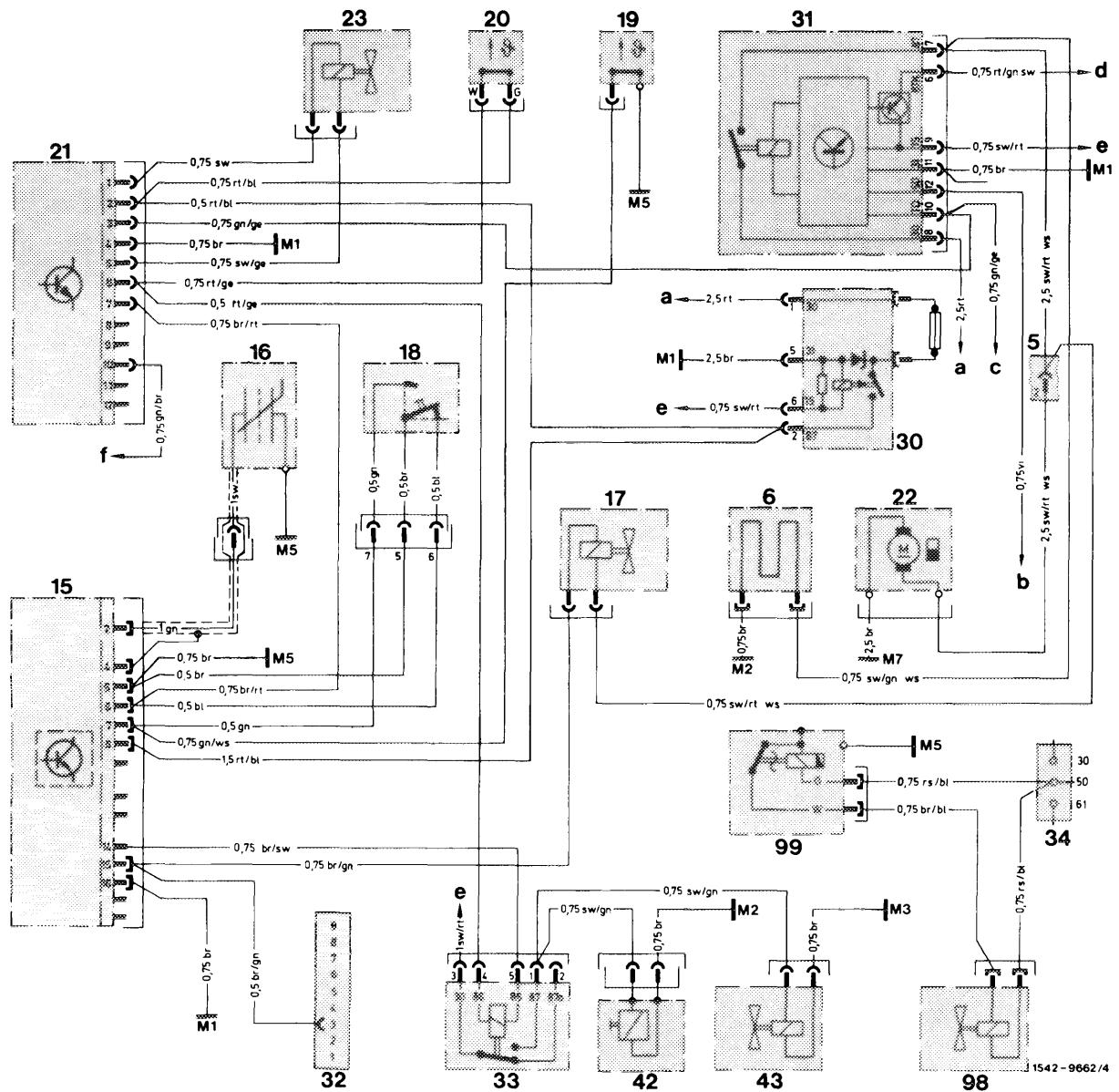

Lambda control, air injection and idle speed control engine 116, model year 1982

- | | | | | | |
|----|--|-----|--|---|--|
| 5 | Plug connection, tail lamp harness (contact 2) | 34 | Engine terminal block | a | Model 107, engine terminal block term. 30 |
| 6 | Warm-up compensator | 42 | Air pump solenoid clutch | b | To ignition starter switch term. 50 |
| 15 | Control unit, lambda control | 43 | Air injection switchover valve | c | To terminal block term. TD |
| 16 | O ₂ sensor | 98 | Cold start valve | d | To connector, starter lockout and backup light switch, contact 7 |
| 17 | Frequency valve | 99 | Thermo time switch | e | Model 107, fuse 5 term. 15 input |
| 18 | Throttle valve switch | M 1 | Main ground (model 107 below right of instrument panel, model 126 behind instrument cluster) | f | To connector, starter lockout and backup light switch, contact 8 |
| 19 | 16 °C oil temperature switch | M 2 | Ground, front right (next to headlamp unit) | | |
| 20 | 42 °C coolant temperature switch | M 3 | Ground, front left wheelhouse (ignition coil) | | |
| 21 | Control unit, idle speed control | M 5 | Ground, engine | | |
| 22 | Fuel pump | M 7 | Ground, right trunk (model 107 fuel tank bulkhead, model 126 on wheelhouse) | | |
| 23 | Idle speed adjuster | | | | |
| 30 | Overtoltage protection relay | | | | |
| 31 | Fuel pump relay | | | | |
| 32 | Diagnostic socket | | | | |
| 33 | Air injection relay | | | | |

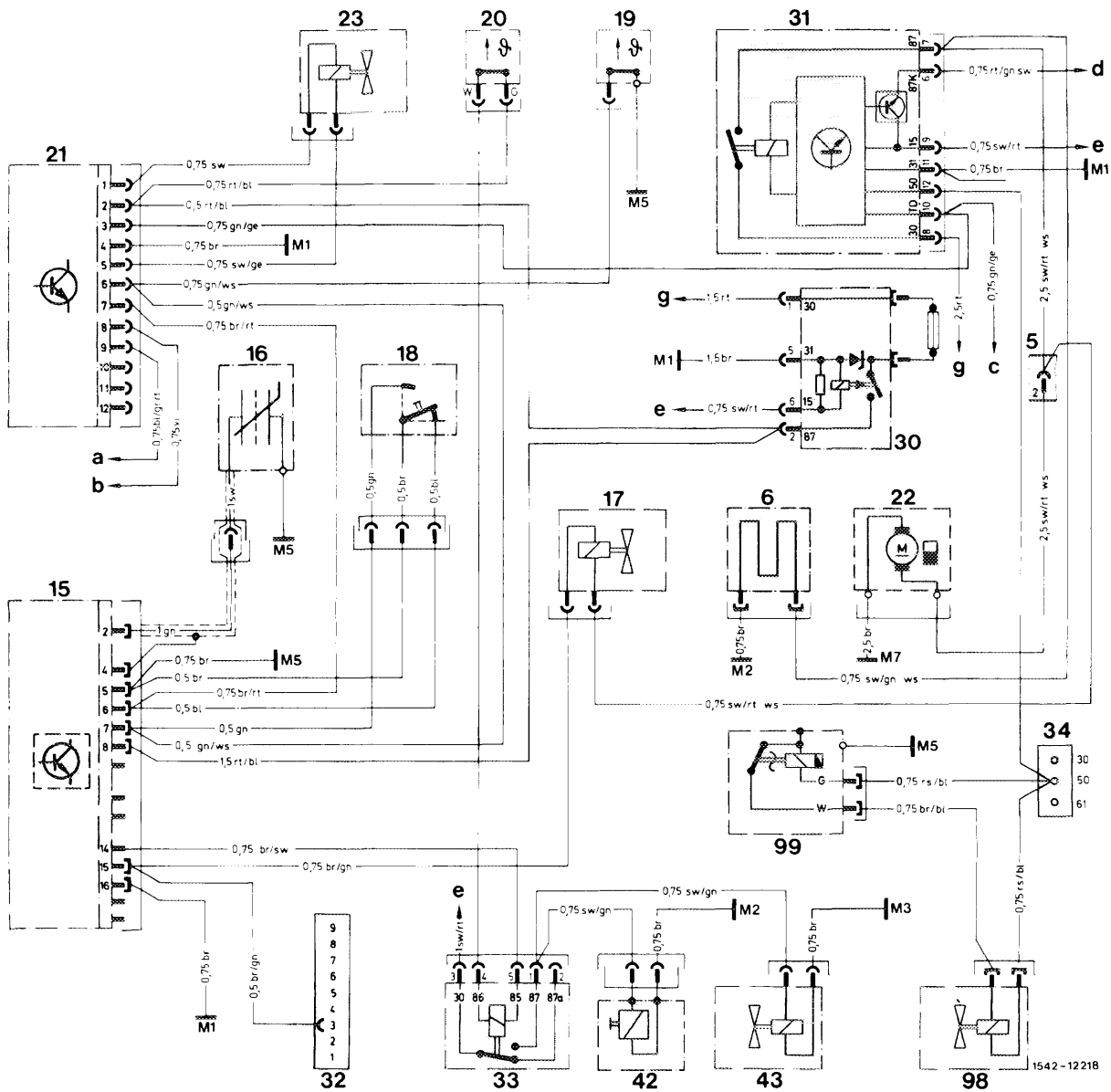

Lambda control, air injection and idle speed control engine 116 starting model year 1983, engine 117 starting model year 1984

- | | | |
|--|--|---|
| <p>5 Plug connection, tail lamp harness (contact 2)</p> <p>6 Warm-up compensator</p> <p>15 Control unit, lambda control</p> <p>16 O₂ sensor</p> <p>17 Frequency valve</p> <p>18 Throttle valve switch</p> <p>19 16 °C oil temperature switch</p> <p>20 42 °C coolant temperature switch</p> <p>21 Control unit, idle speed control</p> <p>22 Fuel pump</p> <p>23 Idle speed adjuster</p> <p>30 Lambda control relay with overvoltage protection</p> <p>31 Fuel pump relay</p> <p>32 Diagnostic socket</p> <p>33 Air injection relay</p> | <p>34 Engine terminal block</p> <p>42 Air pump solenoid clutch</p> <p>43 Air injection switchover valve</p> <p>98 Cold start valve</p> <p>99 Thermo time switch</p> <p>M 1 Main ground (model 107 below right of instrument panel, model 126 behind instrument cluster)</p> <p>M 2 Ground, front right (next to headlamp unit)</p> <p>M 3 Ground, front left wheelhouse (ignition coil)</p> <p>M 5 Ground, engine</p> <p>M 7 Ground, right trunk (model 107 fuel tank bulkhead, model 126 on wheelhouse)</p> | <p>a To supporting point, a/c system</p> <p>b To ignition starter switch term. 50</p> <p>c To terminal block term. TD</p> <p>d To connector, starter lockout and backup light switch, contact 7</p> <p>e Model 107, fuse 5 term. 15 input Model 126, fuse 14 term. 15 input</p> <p>g Model 107, engine terminal block term. 30 model 126, to supporting point fuse box term. 30</p> |
|--|--|---|

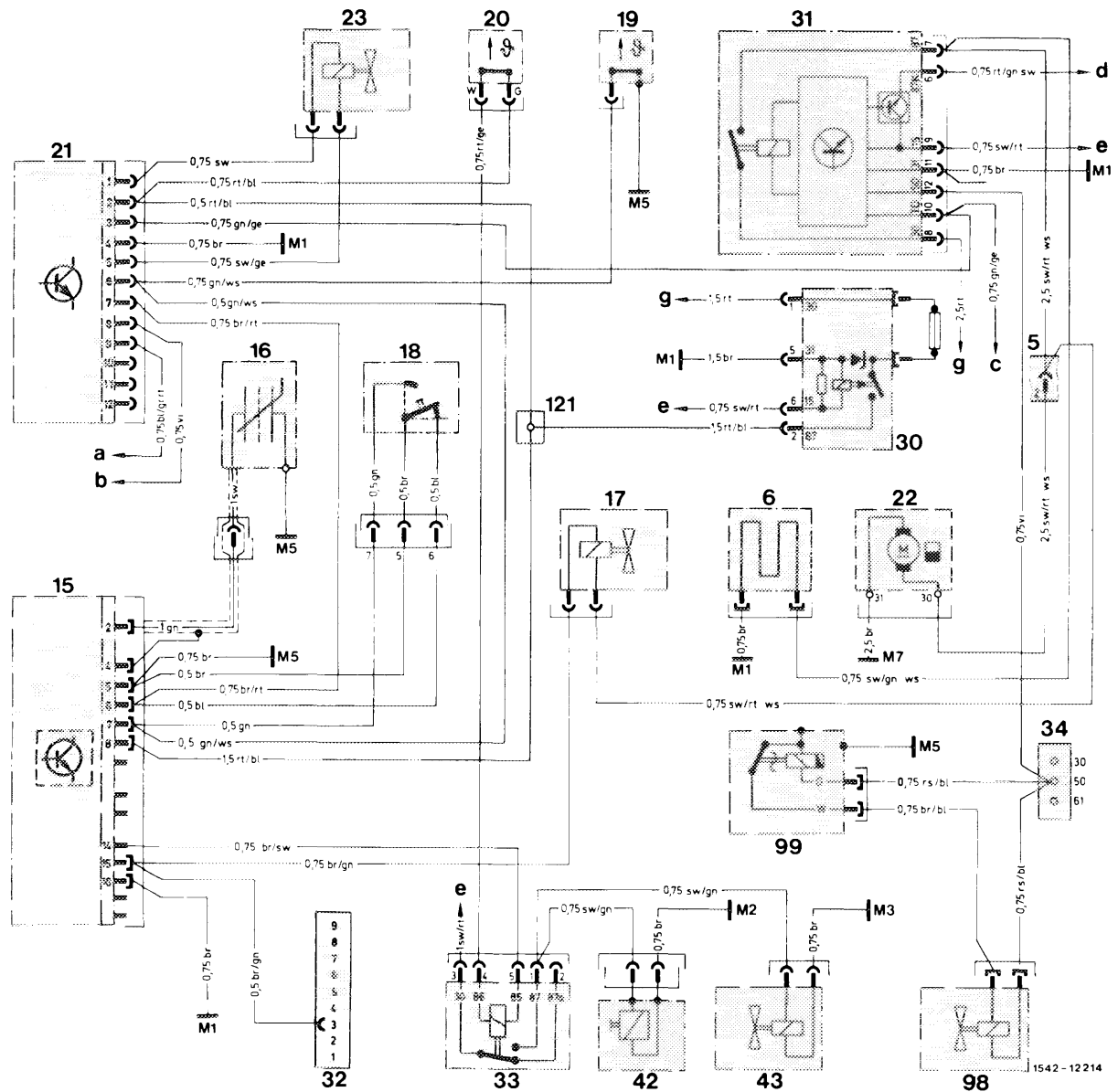

Lambda control, air injection and idle speed control engine 116 basic version NV KAT (closed-loop), engine 116 starting model year 1983, engine 117 starting model year 1984

- | | | |
|---|--|--|
| 5 Plug connection, tail lamp harness (contact 2) | 34 Engine terminal block | a To supporting point, a/c system |
| 6 Warm-up compensator | 42 Air pump solenoid clutch | b To ignition starter switch term. 50 |
| 15 Control unit, lambda control | 43 Air injection switchover valve | c To terminal block term. TD |
| 16 O ₂ sensor | 98 Cold start valve | d To connector, starter lockout and backup light switch, contact 7 |
| 17 Frequency valve | 99 Thermo time switch | e Model 107, fuse 5 term. 15 input Model 126, fuse 14 term. 15 input |
| 18 Throttle valve switch | 121 Terminal block, terminal 87 ABS | g Model 107, engine terminal block term. 30 |
| 19 16 °C oil temperature switch | M 1 Main ground (model 107 below right of instrument panel, model 126 behind instrument cluster) | |
| 20 42 °C coolant temperature switch | M 2 Ground, front right (next to headlamp unit) | |
| 21 Control unit, idle speed control | M 3 Ground, front left wheelhouse (ignition coil) | |
| 22 Fuel pump | M 5 Ground, engine | |
| 23 Idle speed adjuster | M 7 Ground, right trunk (model 107 fuel tank bulkhead, model 126 on wheelhouse) | |
| 30 Lambda control relay with overvoltage protection | | |
| 31 Fuel pump relay | | |
| 32 Diagnostic socket | | |
| 33 Air injection relay | | |

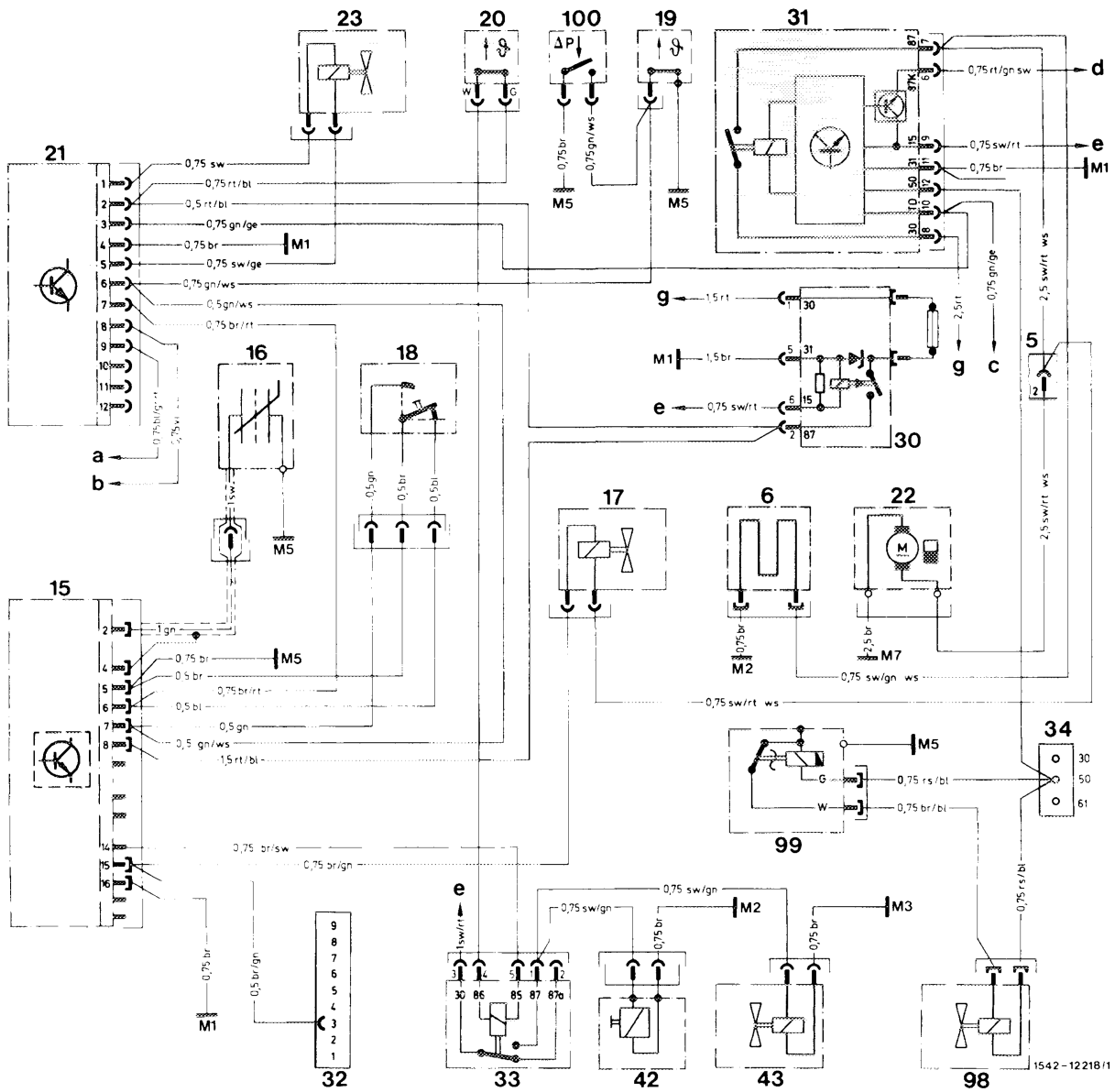

Lambda control, air injection and idle speed control with acceleration enrichment via pressure step switch.
 Engine 116/117 national version (USA) model year 1985

- | | | |
|---|---|--|
| <ul style="list-style-type: none"> 5 Plug connection, tail lamp harness (contact 2) 6 Warm-up compensator 15 Control unit, lambda control 16 O₂ sensor 17 Frequency valve 18 Throttle valve switch 19 16 °C oil temperature switch 20 42 °C coolant temperature switch 21 Control unit, idle speed control 22 Fuel pump 23 Idle speed adjuster 30 Lambda control relay with overvoltage protection 31 Fuel pump relay 32 Diagnostic socket 33 Air injection relay | <ul style="list-style-type: none"> 34 Engine terminal block 42 Air pump solenoid clutch 43 Air injection switchover valve 98 Cold start valve 99 Thermo time switch 100 Pressure step switch M 1 Main ground (model 107 below right of instrument panel, model 126 behind instrument cluster) M 2 Ground, front right (next to headlamp unit) M 3 Ground, front left wheelhouse (ignition coil) M 5 Ground, engine M 7 Ground, right trunk (model 107 fuel tank bulkhead, model 126 on wheelhouse) | <ul style="list-style-type: none"> a To supporting point, a/c system b To ignition starter switch term. 50 c To terminal block term. TD d To connector, starter lockout and backup light switch, contact 7 e Model 107, fuse 5 term. 15 input Model 126, fuse 14 term. 15 input g Model 107, engine terminal block term. 30 model 126, to supporting point fuse box term. 30 |
|---|---|--|